



# Pipe Weld Purge PPM Oxygen Analyzer

The all-new *GPR-1000 WP Pipe Weld Purge PPM Oxygen Analyzer* is designed specifically for pipe welding applications, and features an innovative design and advanced long life electrochemical oxygen sensor that provide highly reliable trace ppm oxygen readings in seconds! Additionally, the cost of ownership is 40% less than competitive analyzers!

Professionals recommend the following oxygen levels before welding commences to prevent oxidation, discoloration, and coking that result in substandard welds:

- ⇒ Below 70 ppm in stainless steel welding
- ⇒ Below 50 ppm in titanium welding
- ⇒ Below 10 ppm in the semiconductor industry

In addition, the benefits of the improving the weld quality by reducing the rest oxygen to trace ppm levels is driving the standards lower in other industries such as aerospace, pharmaceutical, dairy, brewery, chemical, and food processing.

The *GPR-1000 WP* is capable of measuring oxygen levels to meet all of the above requirements. In addition, the *GPR-1000 WP* offers the following invaluable features:

## **Comes Online in Seconds (see reverse)**

- A built-in pump transports sample to the analyzer
- The integral Bypass Valve maintains the oxygen sensor at trace ppm oxygen levels, which enables the *GPR-1000 WP* to come online in seconds from Bypass Mode!

## **1 Week Typical Use on Overnight Charge**

- True portable analyzer with a heavy duty rechargeable battery that provides one week of typical use on a single overnight charge

## **Advanced Electrochemical Oxygen Sensor**

- Long expected life, requires no maintenance
- Specific to oxygen
- Unaffected by moisture or particulate matter
- Replace the sensor like a battery

## **Additional Features:**

- Can be used 24/7 while charging with an AC adapter
- User friendly, menu-driven controls
- Aluminum casing to withstand the rigors and abuse of field work



**GPR-1000 WP Weld Purge Oxygen Analyzer**



- **Increases welder productivity and reduces purge gas waste by coming online in seconds!**
- **Increases welder productivity with a heavy duty rechargeable battery that provides one week of typical use**
- **Weld quality is enhanced by the *GPR-1000 WP*'s ability to accurately and reliably measure trace ppm oxygen levels**
- **Low cost of ownership and unmatched performance!**





# Pipe Weld Purge PPM Oxygen Analyzer

## Bypass Valve Operation:

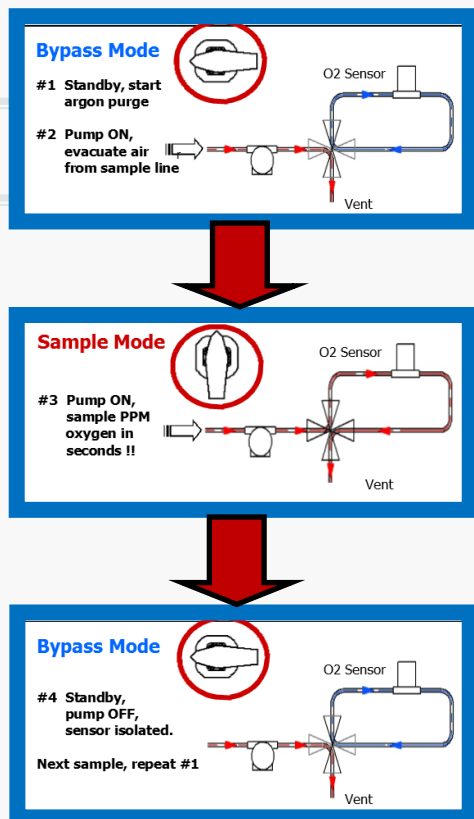

## Setup and Optional Accessory Kit:

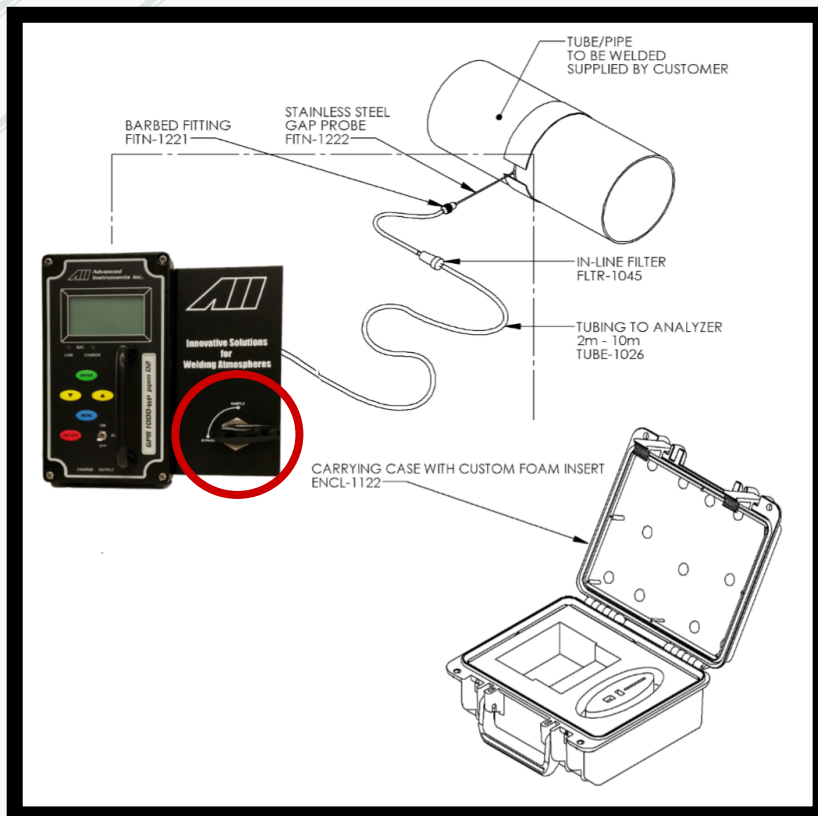

## Technical Specifications

Analysis Range:	0-500 PPM, 0-1%, 0-25%
Accuracy:	< 2% of FS range under constant conditions
Linearity:	±2% of full scale
Signal Output:	0-1V FS
Indicators:	LCD display, resolution 1 PPM; LED indicates LOW BATT and CHARGE mode
Calibration:	Certified span gas with 500-800 ppm O2 or air
Sensor:	GPR-12-100-M PPM Oxygen Sensor
Expected Sensor Life:	24 months
Warranty:	12 months analyzer; 12 months sensor