

45W 4x6 External LED Headlights - Low/High Beams - 10-30V DC - Chrome Reflector

Part #: IL-LED-DLR-4X6



The IL-LED-DLR-4X6 from Larson Electronics is an LED, 4x6 automotive headlight that is a suitable replacement for lighting systems in trucks, cars, tractors and industrial equipment with 4"x6" sealed beam installation holes. This low voltage, 45-watt luminary comes with low and high beam settings and emits a bright white light with a color temperature rating of 6000K. A clear, polycarbonate lens reinforces the exterior of the lamp, allowing it to withstand light impacts.

The IL-LED-DLR-4X6 is a suitable replacement for a wide range of automotive lighting systems. This 45-watt LED lamp operates on 10-30V DC, including 12V DC and 24V DC. When in use, the luminary emits 1,800 lumens (low beam) and 2,600 lumens (high beam). A total of nine LEDs can be found inside the unit. The luminary is constructed of die-cast aluminum and features a polycarbonate lens with IP67 waterproof protection. The back of the IL-LED-DLR-4X6 supports a breathable design for robust air flow. This component prevents the lamp from fogging up in harsh environments. A chrome reflector ensures maximum illumination in dark and hazy conditions.

LED Benefits: Unlike gas burning and arc type lamps that have glass bulbs, LEDs have no filaments or fragile housings to break during operation and/or transportation. Instead of heating a small filament or using a combination of gases to produce light, light emitting diodes (LEDs) use semi-conductive materials that illuminate when electric current is applied, providing instant illumination with no warm up or cool down time before re-striking. Because there is no warm up period, this light can be cycled on and off with no reduction in lamp life.

LED lights run at significantly cooler temperatures than traditional metal halide and high pressure sodium lights and contain no harmful gases, vapors, or mercury, making them both safer and more energy efficient. No extra energy is wasted in cooling enclosed work areas due to external heat emissions from bulb type lights, and the operator risks associated with traditional lighting methods, such as accidental burns and exposure to hazardous substances contained in the glass bulbs, are eliminated. In addition, LEDs are also safer for the environment as they are 100% recyclable, which eliminates the need for costly special disposal services required with traditional gas burning and arc type lamps.

High Quality Features

1. Low power consumption.
2. Instant on/off operation.
3. Superior color rendering compared to HPS, LPS, MH.
4. Solid-state design.
5. Low profile - light weight.
6. 1,800 lumen output from 20 watts.

Superior LED Benefits

1. 50,000+ hour lifespan.
2. Can SAVE 50% or more on energy.
3. Qualifies retrofit projects for financial incentives, including utility rebates, tax credits and energy loan programs.
4. Reduces energy use and prolongs life-spans of peripheral cooling units (A/C, refrigeration)
5. 100% recyclable.
6. No toxins-lead, mercury.
7. No UV light, infrared radiation or CO2 emissions.
8. Qualifies buildings for LED and other sustainable business certifications.
9. Bright, even light maintains consistent color over time.
10. Instant on/off - No flickering, delays or buzzing.
11. Very good color rendering.
12. Vibration/impact resistant.
13. Significantly cooler operation.
14. Less frequent outages, higher output improves workplace safety.

Applications: 1982-1992 Chevy Camaro Iroc-Z, 1979-1993 Ford Mustang, tractors, forklifts, vehicular equipment and all trucks/cars with 4"x6" sealed beam installation holes.

At Larson Electronics, we do more than meet your lighting needs. We also provide replacement, retrofit, and upgrade parts as well as industrial grade power accessories. Our craftsmen can custom build any lighting system and/or accessories to fit the unique demands of your operation. A commitment to honesty, quality, and dependability has made Larson Electronics a leader in the lighting and electronics business since 1973. Contact us today at 800-369-6671 or message sales@larsonelectronics.com for more information about our custom options tailored to meet your specific industry needs.

Specifications / Additional Information

IL-LED-DLR-4X6 45W 4x6 External LED Headlights

Lamp Type: LED

Dimensions: 6.6" x 2.6" x 4.3"

Total Watts: 45W (20W Low Beam, 24W High Beam)

Voltage: 10-30V DC

Lumens: 1800lm (Low Beam), 2600lm (High Beam)

Beam Configuration: Low/High

LED Light Color: 6000K - White

LED Life Expectancy: 50,000+ hours

Ambient Operating Temp Range: -20°C to +60°C

Socket Type: H4

Reflector: Chrome

Lens Material: Polycarbonate

Housing Material: Aluminum

Weight: 7 lbs

Warranty: Yes - 1 Year*

Ratings/Approvals

IP67 Waterproof

1982-1992 Chevy Camaro Iroc-Z

1979-1993 Ford Mustang

Compatible with 4"x6" Sealed Beam Installation Hole

Special Orders- Requirements

Contact us for special requirements

Toll Free: 1-800-369-6671

Intl: 1-903-498-3363

E-mail: sales@larsonelectronics.com

[Scroll Down to Purchase-](#)

[Part #: IL-LED-DLR-4X6 \(147117\)](#)





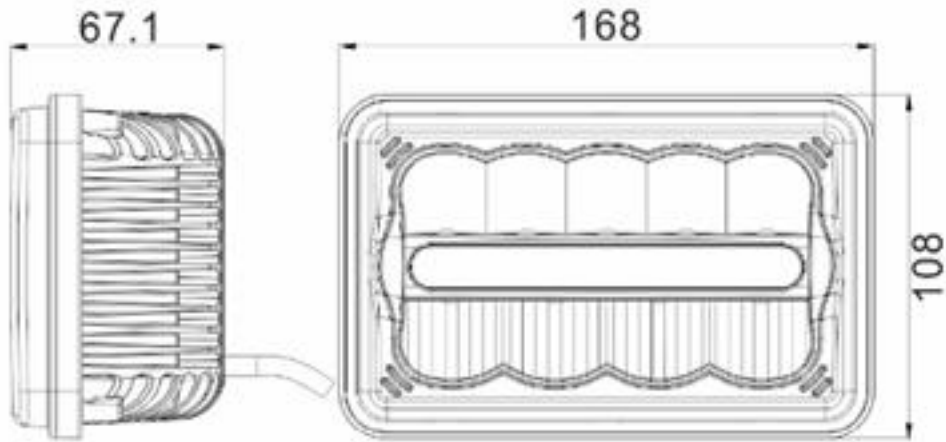

Links (Click on the below items to view):

- [Hi-Res Image 1 - 45W 4x6 External LED Headlights](#)
- [Hi-Res Image 2 - 45W 4x6 External LED Headlights](#)
- [Hi-Res Image 3 - 45W 4x6 External LED Headlights](#)
- [Hi-Res Image 4 - 45W 4x6 External LED Headlights](#)