

## *Model 5H*

Is simple, rugged, and always dependable. Turn it on and it goes right to work, skimming waste oils, mineral and vegetable oils, animal fats, oil froths, and other contaminants from water, coolants and cleaning solutions.

  
**OILSKIMMERS, INC.®**

440.237.4600  
[www.oilskim.com](http://www.oilskim.com)

# MODEL 5H

## 10 REASONS

*Oil Skimmers' Model 5H will save you time and money while solving your oil contamination problems.*

*Oil Skimmers, Inc. was the pioneer in developing an oil skimming system that has proven its effectiveness and long life in tens of thousands of plant operations throughout the world.*

*Our oil skimming products utilize a flexible floating collector tube that is able to snake over and around debris to reach the oil. The tube floats up and down with varying liquid levels. The tube breaks up crusted oil or grease, causing these contaminants to adhere to the tube.*

### 1. **Our unique method of oil removal**

The 5H utilizes a floating tube system. The closed loop tube, made of a flexible, specially formulated plastic, attracts oil but not water. The Model 5-H continuously draws the oil-covered tube through scrapers and returns the clean tube to the water surface to gather more oil. The skimmed oil drains into a collection vessel. The collector tube can be sized to a variety of lengths to fit your particular applications.

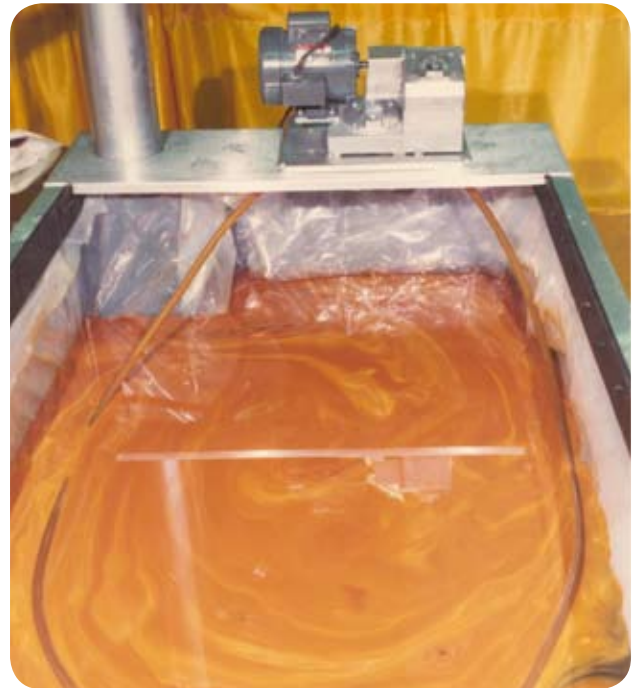
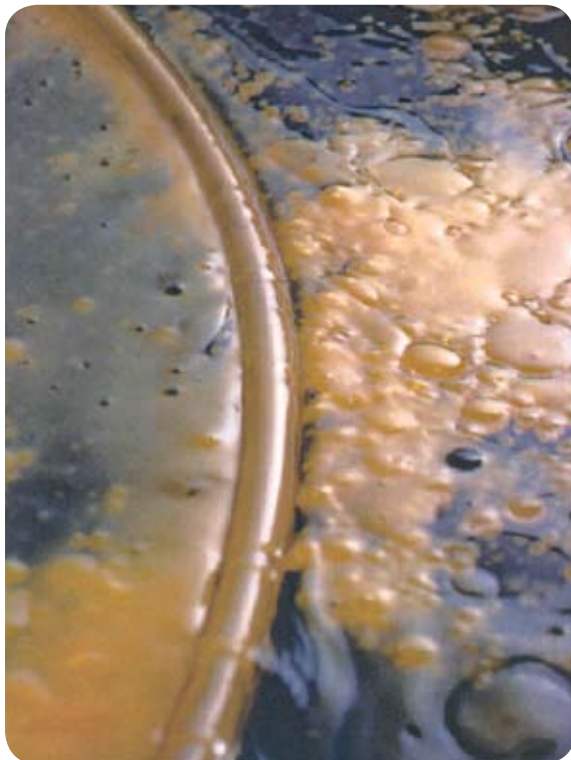

### 2. **Significant cost savings and energy benefits**

The 5H typically pays for itself in a very short time. It offers you savings through reduced labor costs, reduced liquid contamination disposal fees and less chemical treatment cost.

Many of our customers have discovered yet another major financial advantage to our skimmer: the oil it recovers can often be reclaimed for further use or even sold to oil recyclers. Thus, Oil Skimmers Inc. can help you turn your "problem" into a profitable situation in these energy-starved times.



### **3. Free on-location survey and recommendation**

Oil Skimmers will provide a complete on-location survey of your operation's skimming needs, without obligation. Our agents and representatives have been involved in oil skimming projects in countless plant applications throughout the world. They will conduct a simple "tube test" to learn if the Model 5H can recover your oil.

We will be happy to provide you with our engineering manual (or CD) with a section on oil spill control. It contains bulletins on all phases of water/oil separation projects, techniques and guidelines. In short, our 5H skimmers are useful in almost any oil contaminations situation.

### **4. Manufactured by a reliable company with years of experience**

Oil skimming equipment is the only product produced by Oil Skimmers, Inc. Being the leader in the automatic oil skimming field over the past four decades, we have installed tens of thousands of units throughout the world. Our products are being used by large and small companies in a variety of fields.

- Steel and aluminum mills
- Metal machining and manufacturing operations
- Storm water treatment
- Food Processors

- Chemical and oil processing
- Railroads
- Vehicle maintenance and wash facilities

### **5. The perfect solution for tight, hard-to-reach spaces**

The Model 5H is compactly designed and thus is particularly suited for use in limited space situations and congested plant areas.

Typical applications include open and closed tanks used in waste treatment systems, parts washers, and coolant systems.

### **6. Operates 'round the clock**

The 5H likes to work hard. In fact, if you want it to, it will operate unattended 24 hours a day, 7 days a week. No matter how hard it works it never loses its pace.

The 5H can recover your oils no matter what capacity is needed. The higher the viscosity of the containment, the faster the 5H works.

### **7. Picks up oil...not water**

Our collector tube picks up only the oil. Water and other liquids which you wish to retain are not carried off in the process.

A decanter may be added where solution carry-over would be a problem due to frothy emulsions or very small amounts of water present.

The decanter returns the water or coolant back to the process area, sending only the oil to storage.



## 8. Long lasting/low maintenance

The 5H requires virtually no maintenance. The external parts which contact the grit-laden oil on the collector tube are made of special high abrasion resistant ceramic. These include the drive wheel, scrapers and pressure blocks.

Internal components, such as gears and bearings, are of high-strength steel and bronze, and engineered to eliminate stress when in use, and thus require minimal power demands.

You don't have to be a graduate engineer to service the unit. The simple design not only eliminates frequent maintenance, but makes whatever maintenance you may have to perform a 1,2,3 procedure. Oil Skimmers can treat all external metal parts with a Teflon coating for added protection where there is exposure to extreme PH or other harsh environments.

## 9. Pre-fab mounting equipment is easy-to-install

Our skimmer mounts are noted for easy installation. There are no tail pulleys or idler wheels to be hooked up below the surface of the liquid being skimmed. Thus, installation is completed with virtually no "dirty work."

Mounts are available for both open and closed tanks. Our mounts eliminate the need for high-cost structural frames often required with other skimming methods. Customized mounting systems are available to meet your specific need.

## 10. Able to be used in all types of environments

The 5H can be used in either hot or cold applications. The flexible collector tube is made of materials that can be used in freezing conditions or in especially hot applications. Heaters are also available for outdoor use.

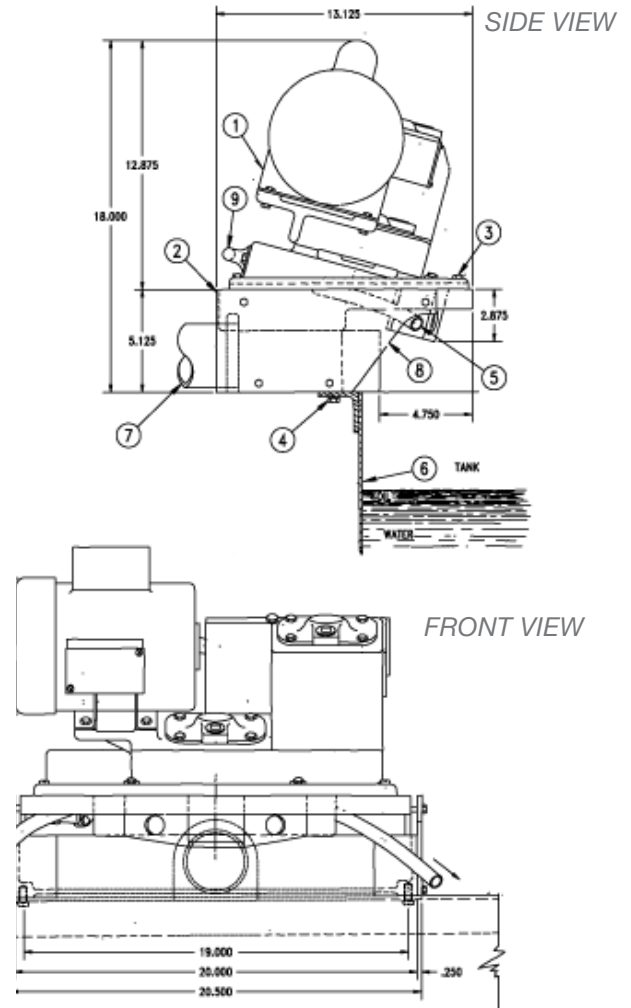

*For other applications, our Model 6V maybe your answer*

*Oil Skimmers Inc. also manufactures a skimmer for the removal of oil from settling ponds, steel mill scale pits, below-floor sumps, and central coolant systems. The unit is called the 6V (see adjoining photo) and is available with a variety of easy-to-install mounting systems. Your Oil Skimmers representative will be happy to discuss with you the best skimmer to fit your needs.*



© Copyright 2008 by Oil Skimmer's Inc.  
® Registered trademarks of Oil Skimmers, Inc.

For further information, call or write:  
OIL SKIMMERS, INC.  
P.O Box 33092  
Cleveland, Ohio 44133 USA  
Phone: (440) 237-4600 Fax: (440) 582-2759  
E-mail: info@oilskim.com